

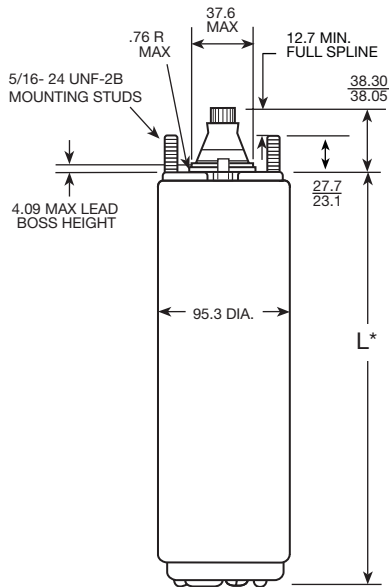

# All Motors

## INSTALLATION

### 4" Super Stainless - Dimensions (Standard Water Well)



### 4" High Thrust - Dimensions (Standard Water Well)

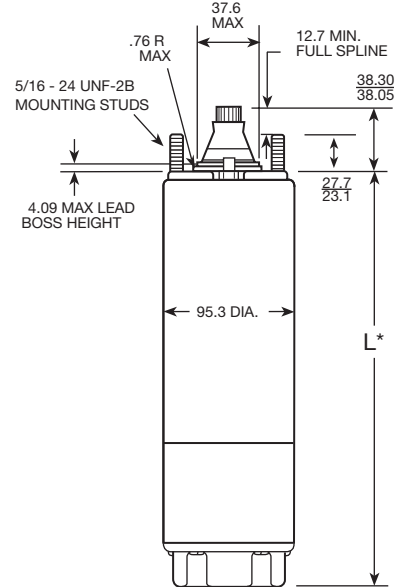

### 6" - Dimensions (Standard Water Well)

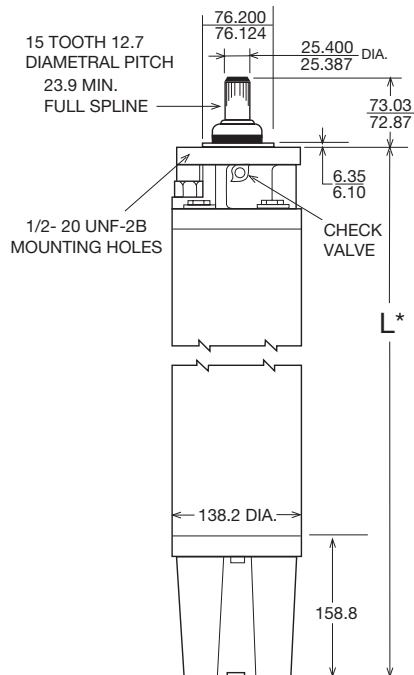

### 8" - Dimensions (Standard Water Well)

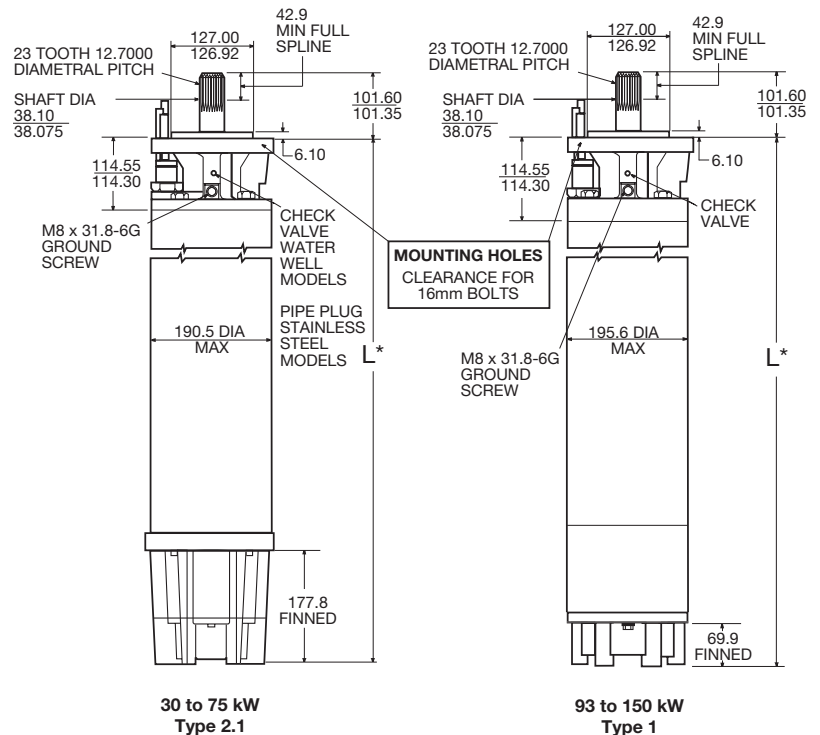

Dimensions in mm unless otherwise noted

\* Motor lengths and shipping weights are available on Franklin Electric's web page ([www.franklin-electric.com.au](http://www.franklin-electric.com.au)) or by calling Franklin on 1300 FRANKLIN.